

NoroGard westrup R1000 Batch Seed Treater

Designed for complex treatments to meet high demands regarding application quality, reliability, operator safety and economy.

Equipped to meet your needs for dressing, incrustation, coating and pelleting of seeds with diameter minimum 2 mm.

Easy operated and controlled with an automatic PLC system.

CAPACITY

27 ton/hour

The integrated scale allows you to vary the size of the batch. The maximum capacity, based on wheat with a hectoliter-weight of 75 kg, and mixing 20 sec per batch, is 27 ton/hour.

NoroGard  westrup

- Speed of rotor and spinning cup can be varied
- Mixing time can be varied
- Opening time of the outlet-hatch can be set
- Pumping time for the dosing pump can be set
- Pump-capacity can be varied
- Save up to 99 seed treatment recipes in our operating system

R1000 Batch Seed Treater



The batch treaters are your obvious choice when you need a more complex treatment like pelleting, application of separate layers with drying in between and for small seeds like vegetable seeds.

Control system with manual calibration is made by pumping the treating liquid to a separate measuring glass in a closed system. When the settings and calibrations are made, the machine runs continuously. It is also possible to get an even more sophisticated supervision system with a larger size touch screen. By adding the ULD Control system to your system you get an automatic calibration of dosage rates for both liquids and powders, and a continuous control of dosage rates.

The R1000 control system provides remote connection via LAN to our service department and/or connection from an optional device like mobilephone, tablet or computer to supervise your operations.

All internet traffic is free during warranty, then you choose between continued support or independency.

The treatment as well as the treaters handling of the treatment liquid, from barrel to treating, takes place in a closed system. The maximum batch size is 200 liter of seed. You can add up to 10 separate liquid dosage systems, make adjustments and operate from a touchscreen with display.

All vital parts are easily accessible for cleaning and service which makes the R1000 fast up and running again after cleaning. By a simple cleaning you prevent the build-up of chemicals in the machine.

With modern complex treatments R1000 will allow you to apply treatment evenly in small dosages for good economy and correct treatment of each seed.

The R1000 is approved for the European CE workers safety standards.

TECHNICAL SPECIFICATION

Power requirement	35 kW
Compressed air [at 5.5 bar]	100 l/min
Air extraction	500 m ³ /h
Capacity [batch volume]	10-200 liters
Capacity [wheat, 20 sec mixing]	27 ton/hour
Weight	1550 kg
Width	1100 mm
Depth	2300 mm
Height	2300 mm
Warranties	Orgalime S2012



The integrated scale allows you to vary the size of the batch.



Our machines are built to last for 20 years.

TECHNICAL SPECIFICATION OPTIONAL CONTROL SYSTEMS

	R1000	R1000 ULD
Scale	PLC assisted. Size of batch can be varied	R1000 ULD Control system Size of batch can be varied
Variable speed of rotor and spinning cup	Option	Option
Varied mixing time	Yes	Yes
Dosage	Pumping time can be set	The pumping time can be set
Calibration	Manually	Automatic calibration of dosage rates for liquids.
Continuous control of dosage rates	-	Yes
Touch screen	10"	15"
Remote access to PLC via LAN	Yes, connect to service and/or remote computer /device	Yes, connect to service and/or remote computer /device
Statistics report	Yes	Yes
Seed treatment recipes	99	99
Outlet-hatch opening time	Can be set	Can be set

OPTIONS

- R1000, Schneider PLC controlled w. our own software including recipe management and manual calibration.
- or
- R1000 ULD, Schneider PLC controlled w. our own software including recipe management and automatic calibration with continuous flow control.
- Up to ten separate dosage units.
- Powder application systems.
- Printer for printing out statistics.
- Pre-mixing station.
- Remote control box consisting of a touchscreen with display and a start/stop handle. This should preferably be placed at the filling-up station.

R1000 BATCH SEED TREATER · MEASUREMENTS

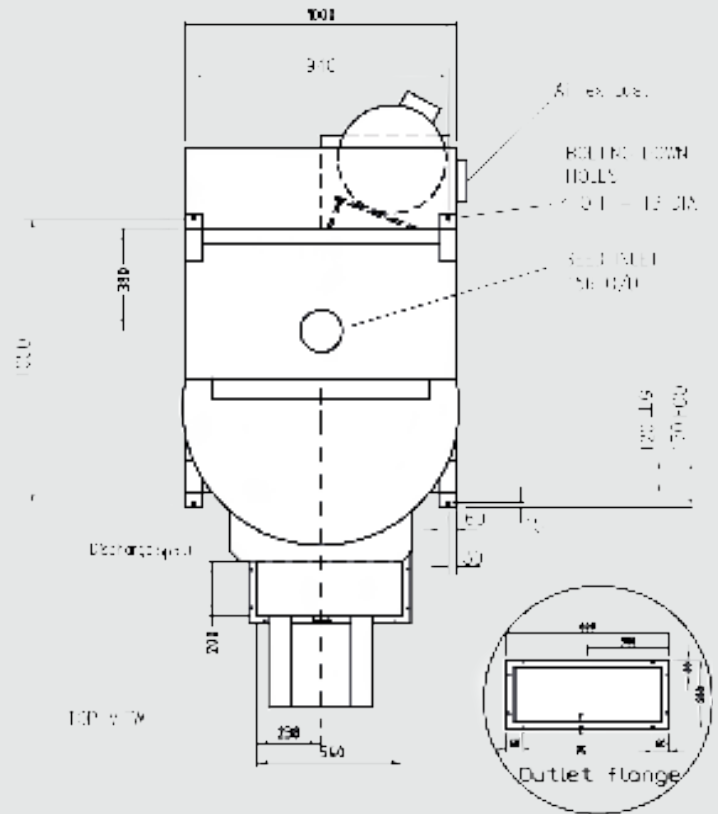
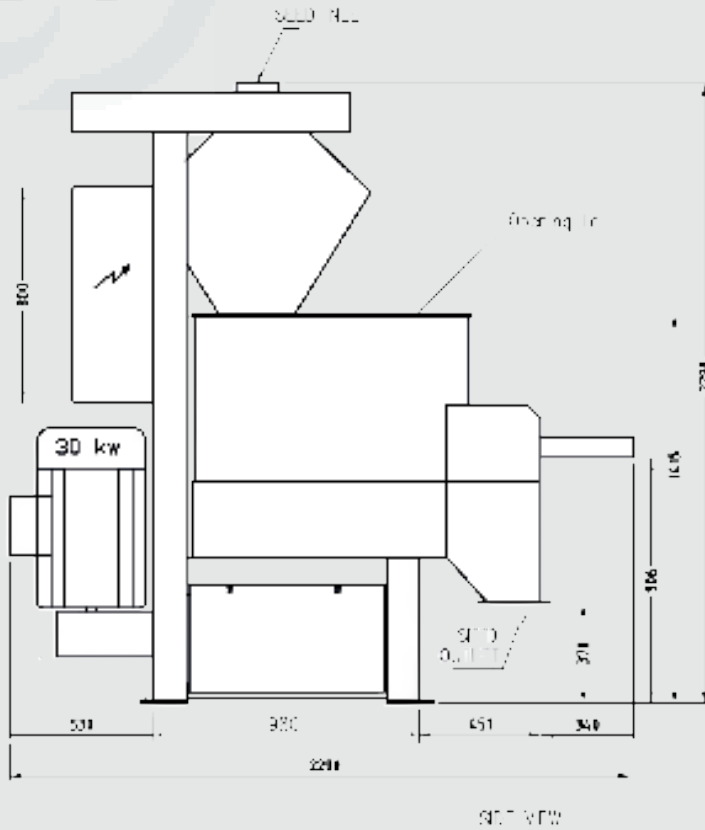

NOROGARD · WESTRUP

NoroGard was founded in Sweden where the development and production of high quality Seed Treatment Equipment began in 1965. In 2022 the production of Seed Treatment Equipment was taken over by Westrup A/S in Denmark under the NoroGard · Westrup fusion.

The NoroGard · Westrup seed treaters are designed to be extremely reliable and built to last for more than 20 years. The NoroGard dosage systems are unique and equipped with pumps and flow meters of our own design, in order to offer you the best possible application quality and reliability.

Personal service and customization is key. NoroGard · Westrup delivers sophisticated Seed Treaters worldwide with personal support. The seed treaters are built to last. Should a standstill occur, we always keep your spareparts in stock.

OUR INNOVATIONS

The NoroGard · Westrup pumps are one of our innovations developed and made in-house and specially designed to perform under tough conditions.

The Diaphragm pump is outstanding in reliability and low maintenance compared to any peristaltic pump on the market.

Our pumps have a pressure equalization for an even flow with less pulses, which insures high dosing accuracy. The pumps are also reversible, easy to operate and have a long life cycle.

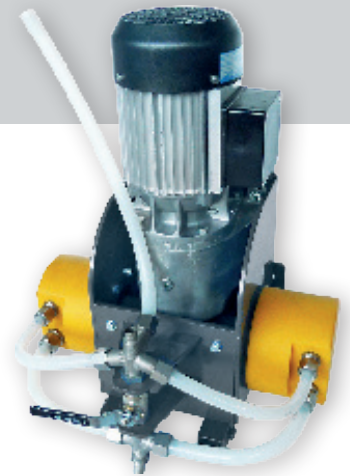

NoroGard · westrup

Westrup A/S,
DK-4200 Slagelse, Denmark
+45 58 52 25 64
info@westrup.com
www.westrup.com