

The R45 Continuous Seed Treater is designed for sophisticated treatments of volume seeds and top of the line application quality.

You can connect remotely with any device through internet and supervise your process for quality control or technical support.

## NoroGard westrup R45 Continuous Seed Treater



CAPACITY  
16,2-40,5 ton/hour

The R45 Continuous Seed Treater is suitable for seed plants with a need for sophisticated treatment of cereals, corn, peas, soybeans, OSR, cotton, sunflowers etc.

NoroGard  westrup

# R45 Continuous Seed Treater



The Continuous Seed Treater meets the requirements for:

- Correct Dosage Rate
- High Application Quality
- Easy to Operate and Clean
- Operator Safety
- Reliability
- High Quality
- Minimal Service Needed

**The Continuous Seed Treater are recommended for production of volume seeds. The treater has an even flow of both seeds and the treating liquids that is continuously measured.**

Control system with manual calibration is made by pumping the treating liquid to a separate measuring glass in a closed system. When the settings and calibrations are made, the machine runs continuously. It is also possible to get an even more sophisticated supervision system with a larger size touch screen. By adding the ULD Control system to your system you get an automatic calibration of dosage rates for both liquids and powders, and a continuous flow control of dosage rates.

The R45 control system provides remote connection via LAN to our service department and/or connection from an optional device like mobilephone, tablet or computer to supervise your operations.

All internet traffic is free during warranty, then you choose between continued support or independency.

The treatment as well as the treater's handling of the treatment liquid, from barrel to treating, takes place in a closed system. You can add up to 10 separate liquid dosage systems, make adjustments and operate from a touchscreen with display.

All vital parts are easily accessible for cleaning and service which makes the R45 fast up and running again after cleaning. By a simple cleaning you prevent the build-up of chemicals in the machine.

With modern complex treatments R45 will allow you to apply treatment evenly in small dosages for good economy and correct treatment of each individual seed.

The R45 is approved for the European CE workers safety standards.

## TECHNICAL SPECIFICATION

Power requirement	12 kW
Capacity [wheat with density 760 kg/m <sup>3</sup> ]	16.2-40.5 ton/hour
Dosage system	4-10 [see options]
Dosage rate [per system]	50-1200 ml/100kg
Weight	750 kg
Width	800 mm
Depth	2540 mm
Height	2070 mm Orgalime
Warranties	S2012



Our technology is built to last for 20 years.



Calibration of the dosage system is easily operated and controlled in a closed system.

## OPTIONS

- R45, Schneider PLC controlled with our software including recipe management and manual calibration.
- or
- R45 ULD, Schneider PLC controlled w. our software including recipe management and automatic calibration with continuous flow control.
- Remote control cabinet consisting of a touch panel and a start/stop button. Should preferably be placed at the filling up station.
- Added separate dosing systems, maximum 10, for liquids. Each dosage system has a capacity of 50-1200 ml/100kg seeds.
- Powder feeding system.
- Double mixing tubes.
- Batch recipes and statistics sent via email.
- Hectolitre weigher to control the hectolitre weight.
- Customization for treatment of grass seed.

## TECHNICAL SPECIFICATION OPTIONAL CONTROL SYSTEMS

	R45	R45 ULD
Continuous control of dosage rates	-	Yes
Touch screen	10"	15"
Remote access to PLC via LAN	Yes, connect to our service department and/or remote computer/device.	Yes, connect to our service department and/or remote computer/device.
PLC Control System	Schneider Electric and our own Control Software	Schneider Electric and our own Control Software
Calibration	Manually	Automatic
Self-cleaning outlet cone	Yes	Yes
Statistics Report	Yes	Yes

# R45 CONTINUOUS SEED TREATER · MEASUREMENTS

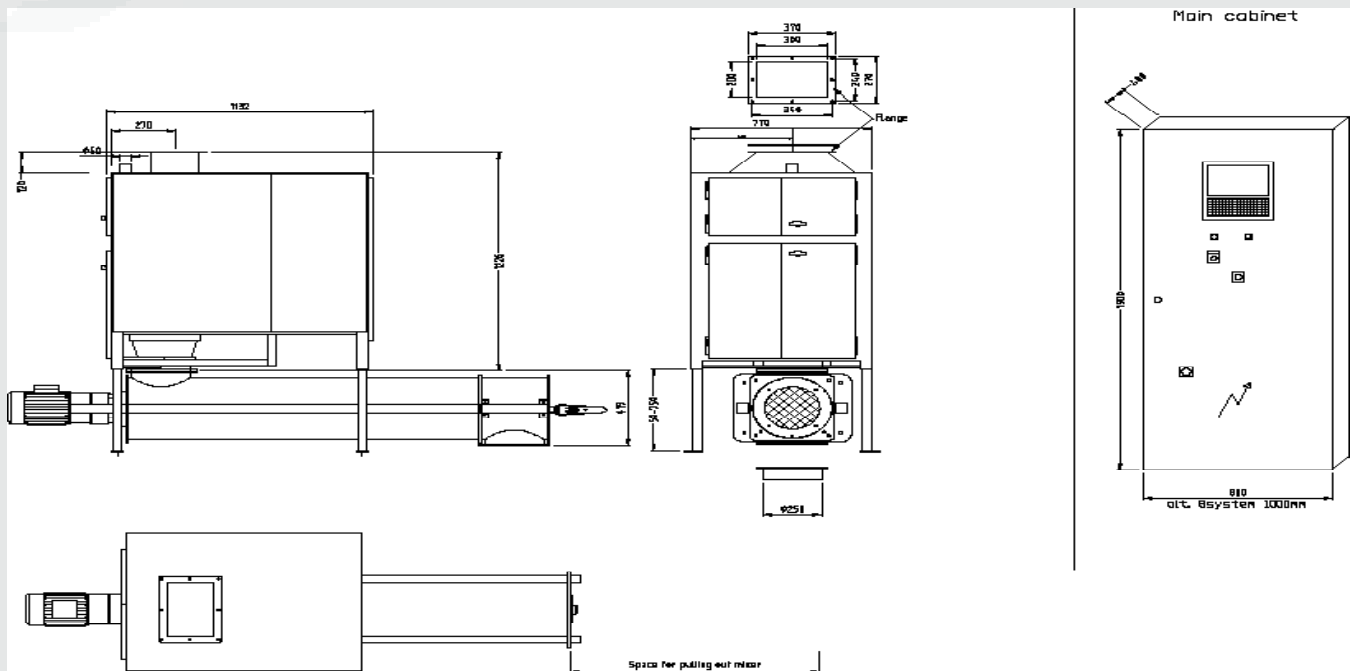

## NOROGARD · WESTRUP

NoroGard was founded in Sweden where the development and production of high quality Seed Treatment Equipment began in 1965. In 2022 the production of Seed Treatment Equipment was taken over by Westrup A/S in Denmark under the NoroGard · Westrup fusion.

The NoroGard · Westrup seed treaters are designed to be extremely reliable and built to last for more than 20 years. The NoroGard dosage systems are unique and equipped with pumps and flow meters of our own design, in order to offer you the best possible application quality and reliability.

Personal service and customization is key. NoroGard · Westrup delivers sophisticated Seed Treaters worldwide with personal support. The seed treaters are built to last. Should a standstill occur in spite, we always keep your spareparts in stock.

## OUR INNOVATIONS

The NoroGard · Westrup pumps are one of our innovations developed and made in-house and specially designed to perform under tough conditions.

The Diaphragm pump is outstanding in reliability and low maintenance compared to any peristaltic pump on the market.

Our pumps have a pressure equalization for an even flow with less pulses, which insures high dosing accuracy. The pumps are also reversible, easy to operate and have a long life cycle.

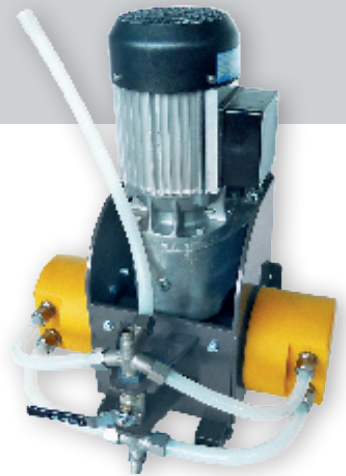

# NoroGard · westrup

Westrup A/S,  
DK-4200 Slagelse, Denmark  
+45 58 52 25 64  
info@westrup.com  
www.westrup.com